

Key features

- Based on LED-technology
- 20 000/ 2 000 cd effective flashing white
- Extremely reliable - long lifetime
- Very low power consumption
- Stabilised light output
- Lightweight and small – low wind load factor
- Easy to install
- Patented
- Very low total lifetime costs
- Comes with five (5) years warranty
- Over 10 year continuous, maintenance free operating time
- Controlled by Obelux LHC Light Head Controller

Specifications met

- FAA Advisory Circular 150/5345-43F 09/12/06: L-865, L-864, L-866 and L-885 light unit
- ICAO International Standards and Recommended Practices: Aerodromes - Annex 14 Volume 1, 5th Edition, July 2009, Chapter 6: Medium-intensity, Type A Fixed Obstacle Light
- Certified by STAC France and FVT Germany

Optical characteristics

- 20 000 cd effective intensity @ day mode
- 2 000 cd effective intensity @ night mode
- Colour aviation white
- Horizontal radiation pattern 360°
- Vertical radiation pattern 3°

Electrical characteristics (with LHC)

- Operating voltages 24 or 48 V_{DC}, 100, 115, 200 or 230 V_{AC}
- Constant power input by active PFC
- Flash rates: 20, 40 and 60 fpm
- Flash durations: 100, 150, 200 and 250 ms
- Power consumptions @ 20 fpm, 100 ms:
 - Day mode: 65 VA
 - Night mode: 30 VA
- LED supply current stabilised by constant current generator

Mechanical characteristics

- Anodised marine grade aluminium body
- Glass cover
- Degree of protection IP65
- Operating temperature range -40...+55 °C
- Height 500 mm, diameter 255 mm
- Mounting set -V or -H include
- Light unit weight 20 kg without mounting set
- Mounting set weight 4 kg
- Wind load 1200 N with mounting set @ 200 km/h

Made in Finland

T



Obelux MI-20KW+2KR without mounting set

Order codes:

- Obelux MI-20KW+2KR-V with vertical mounting set
- Obelux MI-20KW+2KR-H with horizontal mounting set

Mounting set -V. Mounting to vertical pipe:

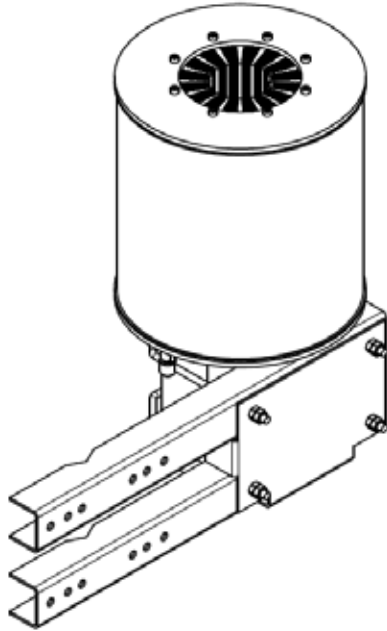

Mounting set -H. Mounting to horizontal surface:

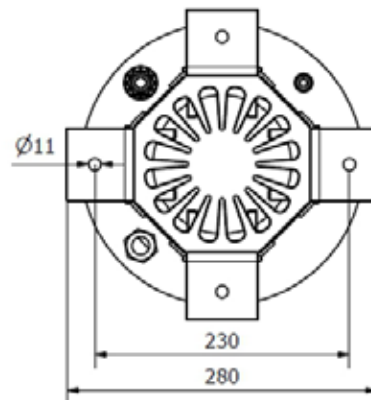
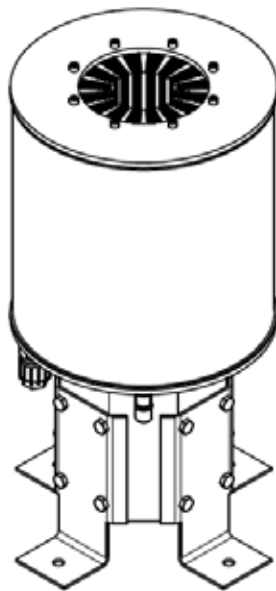

INSTALLATION INSTRUCTIONS

LIGHT HEAD TERMINAL BOX CONNECTIONS

Obelux MI-20KW+2KR light head is connected to light head controller, LHC, via terminal box included in light head. LHC provides light head's supply voltage and flash control with separate cables which are connected to light head's terminal box.

Terminal box connection instructions and cable recommendations:

To lamp	Power in	Control in
4x2,5 + 4x1 mm²	3x6 mm²	CAT5
1 = DC+	br = DC+	or/wh = 20KW SYNC+
2 = DC-	bk = DC-	or = 20KW SYNC-
3 = NC	wh = NC	gr/wh = 2KR SYNC+
ye/gr = PE	shield = PE	gr = 2KR SYNC-
5 = 20KW SYNC+		
6 = 20KW SYNC-		
7 = 2KR SYNC+		
8 = 2KR SYNC-		
shield = PE		

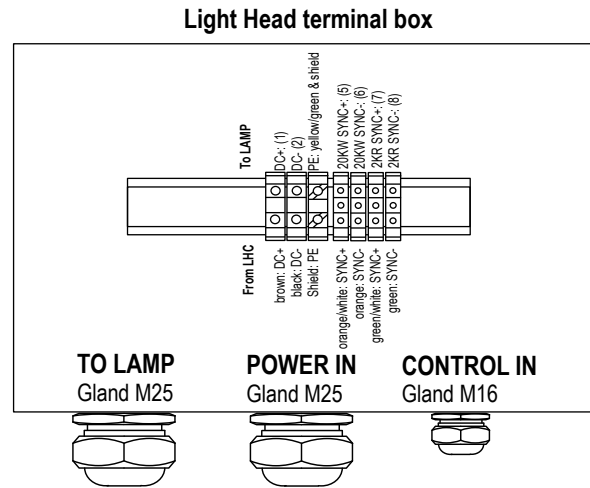

POWER AND CONTROL CABLES

